



NAPA SANITATION DISTRICT

RECYCLED WATER USERS' GUIDE

November 13, 2008

This page intentionally left blank.

TABLE OF CONTENTS

I.	INTRODUCTION	
A.	Purpose.....	I-1
B.	Authority and Sources.....	I-1
C.	Severability	I-2
D.	Definitions.....	I-2
II.	PLANNING FOR RECYCLED WATER USE	
A.	Availability of Recycled Water	II-1
B.	Protection of Public Health and Environment	II-1
C.	Shortages/Outages.....	II-1
D.	Transfer of Service.....	II-2
E.	Procedures for Obtaining Recycled Water Service	II-2
	1. Application Procedure	II-2
	2. Application for Service	II-2
	3. Approval of Service	II-3
	4. Recycled Water Rate and Billing.....	II-3
	5. Rates for Unauthorized Use	II-4
III.	DESIGN CONSIDERATIONS FOR RECYCLED WATER USE	
A.	Introduction.....	III-1
	1. General.....	III-1
	2. Control of Irrigated Areas and Runoff.....	III-1
	3. Irrigation Times	III-2
	4. Temporary Connection to Potable Water Service	III-2
B.	Submittal and Approval Process	III-2
	1. Approvals.....	III-2
	2. Record Drawings	III-3
	3. Irrigation Equipment Legend.....	III-3
C.	General Considerations for Use.....	III-3
	1. NSD Access	III-3
	2. Public Access	III-4
	3. Posting of Use Areas.....	III-4
	4. Prevention of Overspray, Runoff and Ponding.....	III-4

TABLE OF CONTENTS

5.	Sensitive Areas.....	III-5
6.	Uses from Domestic Water System	III-5
7.	Conversion of Existing Irrigation Systems to Recycled Water	III-5
D.	Design Requirements	III-6
1.	General.....	III-6
2.	System Pressure	III-6
3.	Pressure Regulator	III-6
4.	Backflow Prevention.....	III-6
5.	Separation Requirements	III-7
6.	Crossings – Sleeves.....	III-8
7.	Pipe and Dig In Protection.....	III-8
8.	Depth of On-Site Recycled Water Piping.....	III-9
9.	Flushing.....	III-9
10.	Hose Bibs	III-9
11.	Washdown Hydrants and Other Points of Public Access	III-9
12.	Quick-Coupling Valves	III-10
13.	Flow Meter.....	III-10
14.	Strainers	III-10
15.	Control and Regulating Valves - Recycled Water System	III-11
16.	Pipe Identification.....	III-11
17.	Valve Boxes	III-12
18.	Irrigation Controllers	III-12
19.	Irrigation and Water Feature Advisory Signs	III-13
20.	Miscellaneous Hardware and Appurtenances	III-13
E.	Inspection.....	III-13
1.	Construction Inspection	III-13
2.	Cross-Connection Test.....	III-13
3.	Final Inspection and Approval to Receive Recycled Water	III-14
IV.	OPERATIONS & MAINTENANCE	
A.	Backflow Assembly Monitoring	IV-1
B.	General Customer Responsibilities	IV-1
1.	Prohibitions	IV-1
C.	MONITORING AND REPORTING	IV-2
1.	General.....	IV-2

TABLE OF CONTENTS

2.	Violations	IV-2
3.	Users' Monitoring Reports	IV-3
D.	User Supervisor	IV-4
1.	User Supervisor Designation	IV-4
2.	User Supervisor Training	IV-5
3.	Changing the User Supervisor	IV-5
4.	User Supervisor Responsibilities	IV-5
5.	Personnel Training	IV-7
E.	Emergency Cross-Connection Procedures	IV-7

APPENDICIES

Appendix A - Figures

- Typical Recycled Water Backflow Prevention Device Installation
- System Separation Requirements: Pipe Separation
- System Separation Requirements: Common Trench
- Dig In Protection Installation
- Sleeving Of Recycled Water Piping
- Recycled Water Sign
- Observations Station Map (Example)

Appendix B - Forms

- Application for Connection to Recycled Water Service
- Designation of User Supervisor
- Recycled Water Backflow Protection – Environmental Assessment Information Sheet
- Recycled Water Supervisor's Initial and Monthly Cross-Connection Monitoring Form
- Permanent Service Recycled Water Use Permit
- Recycled Water User Self-Monitoring Report
- Recycled Water User Notice of Non-Compliance
- Guidelines for Worker Protection at Water Reclamation Use Areas

This page intentionally left blank.

I. INTRODUCTION

A. Purpose

This document provides existing and potential users of recycled water from the Napa Sanitation District (NSD) guidance for the design and operation of on-site recycled water facilities. The provisions of this manual govern the commencement of recycled water service, the conditions of such service and the requirements which must be followed for such service to continue.

NSD has published this manual making every effort in adhering to existing rules, codes, laws and statutes governing the construction and operation of on-site recycled water facilities.

B. Authority and Sources

The use of recycled water is governed by many different agencies. For the user of NSD's recycled water, we have tried to include only those items necessary to design and operate the User's on site system. However, this document is only a summary, and the actual statutes or regulations have precedence.

This manual may be revised at any time as needed to address changes in laws or regulations concerning recycled water, to enhance the reliability of the recycled water system, or to further protect the public health and environment.

NSD will not be liable for any errors or omissions in this manual that result from changes in the CCR or General Reuse Order 96-011, which are beyond the approval of NSD.

A listing of the requirements applicable to either the User or NSD follows:

- The State of California established criteria for the production, distribution and uses of recycled water promulgated through Titles 17 and 22 of the California Code of Regulations (CCR).
- The San Francisco Regional Water Quality Control Board has issued General Water Reuse Order 96-011, which governs NSD's operations and, by extension, the operations of the Users of NSD's recycled water.
- NSD issues individual permits to each User that may differ from other user's permits depending on specific site characteristics.

Specific sections of these titles pertaining to water reuse are available to NSD recycled water users or other interested individuals upon request.

C. Severability

If any clause or provision in this User's Guide is or becomes illegal, invalid or unenforceable because of present or future laws the remaining portions of these rules and regulations shall remain in effect.

D. Definitions

Air Gap Separation – A physical separation between the free flowing discharge end of a water supply pipeline and an open or non-pressure receiving vessel. An approved air gap must be at least twice the diameter of the water supply pipe measured vertically above the overflow rim of the vessel, and in no case less than one inch.

Applicant – any person, firm, corporation, association, or agency that desires, or is required by NSD, to obtain recycled water service.

Automatic System – in reference to landscape irrigation systems includes automatic controllers, valves and associated equipment required for the programming of effective water application rates when using recycled water.

Auxiliary Water Supply – shall mean any water supply on or available to the premises other than NSD's recycled water supplies.

Coagulated Wastewater – Oxidized wastewater in which colloidal and finely divided suspended matter have been destabilized and agglomerated upstream from a filter by the addition of suitable floc-forming chemicals.

Composite Sample – A sample composed of individual grab samples taken from a single sampling location, mixed in proportions to the instantaneous rate of waste flow corresponding to each grab sample (with proportions varying by not more than plus or minus five percent from the instantaneous rate), and collected at regular intervals not greater than one hour, or collected by the use of continuous automatic sampling devices capable of attaining the proportional accuracy stipulated above throughout the sampling period (e.g., 24 hours).

Conventional Tertiary Treatment – A treatment chain that utilizes a sedimentation unit process between the coagulation and filtration processes and produces an effluent that meets the definition for disinfected tertiary recycled water.

Customer – see *User*.

Design Area – shall mean the specific land area designated to be irrigated through on-site facilities when used in reference to irrigation systems.

Disinfected Wastewater – Wastewater in which the pathogenic organisms have been destroyed by chemical, physical or biological means.

Distributor – A municipal or water service agency which receives recycled water from a Producer for the purpose of distribution to users. The Distributor may provide additional treatment to the water, depending upon the intended use.

District – see *NSD*.

Landscape Impoundment – A body of water which is used for aesthetic enjoyment or landscape irrigation or which otherwise serves a similar function and is not intended to include public contact.

NSD – Napa Sanitation District.

Nonrestricted Recreational Impoundment – An impoundment of recycled water, in which no limitations are imposed on body-contact water recreational activities.

On-site Facilities – shall mean facilities under the control of the applicant, owner, or customer including but not limited to residential or commercial landscape irrigation systems, and agricultural irrigation systems. For recycled water service, the on-site facilities shall normally be those downstream of NSD's meter.

Off-site Facilities – shall mean facilities under the control of NSD, including recycled water pipelines, reservoirs, pumping stations, manholes, valve connections, treatment facilities, and other appurtenances and property up to the point of connection with the customer's facilities. For recycled water service, the off-site facilities shall normally be those upstream of NSD's meter and the meter box.

Oxidized Wastewater – Wastewater in which the organic mater has been stabilized, is nonputrescible, and contains dissolved oxygen.

Producer – see *NSD*.

Recycled (Reclaimed) Water – as defined in §13050 of the California Water Code, means water which as a result of treatment of waste, is suitable for the direct beneficial use or a controlled use that otherwise would not occur and is therefore considered a valuable resource.

Service Connection – shall mean the piping necessary to conduct water from NSD's water main to the particular property designated in the application for water service including the meter, meter box, valves and piping equipment within the meter box.

Unit – is 1,000 gallons of water

Use Site Area – An area or recycled water use with defined boundaries. A use site area may contain one or more facilities.

User – shall mean any person, firm, corporation, association, or agency who receives recycled water service from NSD.

User Supervisor – A person designated, by the owner or manager of the property upon which recycled water will be applied, to discharge the responsibility of the owner or manager of the property for:

- (a) installation, operation and maintenance of a system that enables recycled water to be used;
- (b) for prevention of potential hazards;
- (c) implementing and complying with conditions of all Water Reuse Orders/Permits and associated documents; and
- (d) coordination with the cross-connection control program of the supplier of drinking water and the local health/environmental health agency.

II. PLANNING FOR RECYCLED WATER USE

A. Availability of Recycled Water

NSD will from time to time determine the points at which it will deliver recycled water for use by its consumers. Determinations shall be made solely by NSD on the basis of availability of a dependable supply of recycled water, the feasibility of the distribution thereof to the point of delivery, and the water requirements of the consumer.

At the discretion of NSD, the use of recycled water for irrigation or other industrial purposes may be required as a condition of connection to NSD for sewer service.

B. Protection of Public Health and Environment

The User shall cooperate with NSD, the local potable water supplier, and the local Health Department if, in any of their discretion and with respect to the operation of the customer's recycled water system, actions are necessary to safeguard the public health.

If real or potential hazards are evidenced any time during construction or operation of the recycled water system, the local potable water supplier reserves the right and has the authority to terminate recycled water service immediately, without notice. These hazards include, but are not limited to, cross-connections with the potable system, improper tagging, signing, or marking, or unapproved/prohibited uses. The local potable water supplier may elect to temporarily replace the recycled water supply with potable water only after the customer's recycled water system has been disinfected and approval has been granted by NSD and State DHS. All modifications required to replace the recycled water supply with potable water will be at the customer's expense.

C. Shortages/Outages

Recycled water supplies are inherently reliable even during periods of low potable water supplies. However, the process of producing recycled water is energy, equipment, chemical and labor intense. Extended outages of recycled water are rare, but may occur.

In the event of a shortage or outage, NSD will make every reasonable effort to ensure that Users receive enough water to maintain their investments in plantings until normal deliveries are resumed. NSD has no liability for failure to deliver water during shortages or outages.

D. Transfer of Service

Once a service has been connected to recycled water, NSD will not allow a recycled water service to be terminated and reconnected to the potable water system except for special circumstances. Note that any type of cross connection between potable water facilities and on-site recycled water facilities is forbidden.

E. Procedures for Obtaining Recycled Water Service

1. Application Procedure

An application for service shall be made in writing, signed by the applicant, and owner, if not one and the same.

The applicant for service must agree to comply with the requirements of any and all applicable Federal, State, and local statutes, ordinances, regulations, and other requirements. NSD may at its discretion, require specific prior approval of any permit by any Federal, State, or local agency having jurisdiction over or an interest in the operation of NSD's facilities.

Upon receipt of an application, NSD shall review the application and make such investigation relating thereto as necessary. NSD may prescribe, in writing to the applicant, requirements as to the facilities necessary to be constructed, the manner of the connection, the financial requirements and the use of the service, including the availability of adequate on-site recycled water facilities to insure initial and future continued compliance with NSD's regulations and any other applicable requirements.

2. Application for Service

No person shall make a connection to the recycled water facilities of NSD without a service issued by NSD.

Persons desiring or required to obtain service shall make application for a recycled water service by filling out the following forms and agreements:

- "Application For Connection to Recycled Water Service"
- "Recycled Water Backflow Protection – Environmental Assessment Information Sheet"
- "Agreement For the Purchase and Sale of Reclaimed Water"
- "Designation of User Supervisor"

Applicant shall also supply the District with On-site Landscaping and irrigation Piping Plans. Additional on-site construction plans may be required.

Copies of all applications, permits, forms, monitoring reports, etc., shall be sent upon request to the potable water supplier of the site.

3. Approval of Service

Upon approval of NSD, a “Permanent Service Recycled Water Use Permit” shall be issued. The service shall entitle the applicant to receive recycled water service upon the terms and conditions of NSD. Prior to approval of service the User shall demonstrate to NSD and the potable water supplier that no cross connection exists between the potable water system and the reclaimed water system. A “Recycled Water Supervisor’s Initial and Monthly Cross Connection Monitoring Form” shall be completed and returned to NSD and the potable water supplier.

The User shall be liable for all changes to their system, prohibitions associated with the use of recycled water, any and all legal actions which may result from such use of recycled water.

Violation of any rules or regulations relating to the use of recycled water shall initiate corrective action and may result in the revocation of the users permit.

4. Recycled Water Rate and Billing

All consumers on metered recycled water services shall pay a rate as set forth in the Agreement for the Purchase and Sale of Recycled Water.

Some Users may be required to install telemetry equipment on their recycled water meters in order to transmit daily water usage. Users that have meters that do not transmit daily water usage shall read the meters each day water is used. User shall provide NSD, no later than the 5th day of the following month, daily water usage.

Billing of recycled water use will be once a month. The rate for recycled water shall be as spelled out in the Agreement for the Purchase and Sale of Recycled Water.

5. Rates for Unauthorized Use

The rate for unauthorized use of NSD water shall be three times the regular water charges and rates otherwise applicable. “Unauthorized use” includes use of any NSD water without having made application to NSD for water service. Violators shall be liable for the service from and after the date of the last recorded meter reading, or from and after the date of any previous meter reading that may more nearly coincide with the actual date the service was first used by the consumer. Anyone using water not metered pursuant to application shall be liable for the estimated amount of water taken as determined by NSD from all available evidence.

III. DESIGN CONSIDERATIONS FOR RECYCLED WATER USE

A. Introduction

1. General

Consideration should be given to the type of landscaping and selection of plant materials to accommodate good irrigation practices in the recycled water use area. Irrigation design must address specific recycled water management criteria including prevention of overspray onto adjacent sites, runoff and ponding.

In general, the recycled water irrigation system shall be designed to safely and efficiently apply recycled water to the intended use area. General guidelines are:

1. Minimize overspray and runoff.
2. Direct irrigation water away from sensitive areas.
3. Select heads and pressures that minimize atomization or misting.
4. Maximize physical separation between domestic and recycled piping systems.
5. Schedule irrigation around sensitive areas at times of least public exposure and maximum dry out period.
6. Use of low trajectory or non-spray type heads around sensitive areas.
7. Efficient irrigation design.

In sensitive areas, special consideration should be given to the following:

1. Use of decorative shielding or screening.
2. Non-irrigated buffer zones.
3. Use of plant materials that can be irrigated using drip or some method of non-spray irrigation.

2. Control of Irrigated Areas and Runoff

In accordance with the prohibition on runoff and for control of the areas to which recycled water is applied, the design of irrigation systems shall conform to the following:

1. The on-site recycled irrigation system shall be designed to meet the peak moisture demand of all plant materials used within the designated use area.
2. On-site recycled irrigation systems shall be designed to prevent or minimize discharge onto areas not under control of the customer. Part

- circle sprinklers shall be used adjacent to roadways and property lines to confine the sprinklers to the designated use area.
3. The design of the on-site recycled irrigation system shall provide for watering during the periods of minimal use of the service area to the extent possible. Consideration shall be given to allow a maximum dry out time before the designated area is used by the public.
 4. Recycled water shall be applied at a rate which does not exceed the infiltration rate of the soil, thereby avoiding potential runoff. Where varying soil types are present, the design of the recycled irrigation system shall be compatible with the lowest infiltration rate present.

3. Irrigation Times

According to public health standards, irrigation using recycled water should take place at the time of least public exposure and allow maximum dry out time for those areas receiving public contact. To avoid overloading NSD's distribution system, the irrigation demand should be spread evenly over a maximum period as long as it poses no public health threat. NSD reserves the right to assign irrigation times if peak irrigation demands result in a significant loss of NSD's system pressure.

4. Temporary Connection to Potable Water Service

Generally, it is preferred that all irrigation takes place from the recycled water system. However, situations may arise where it is desirable or prudent to irrigate using potable water. If this is the case, care must be exercised to protect against inadvertent cross connection with the recycled water system.

Also, recycled water is only to be used for those purposes specifically permitted in the Permit. If water is needed for purposes not covered by the NSD Permit, then potable water from the domestic water system must be used. Hose bibs and/or quick couplers should be provided on the domestic water system for these purposes.

B. Submittal and Approval Process

1. Approvals

Construction Approval, Follow-up and On-site Inspections Prior to Construction will be made by NSD. Two complete sets of plans and specifications shall be submitted to NSD for approval. One approved District will sign originals. Any field

changes shall be brought to the attention of NSD for approval. A complete set of “as built” reproducibles shall be delivered to NSD upon completion of the project.

2. Record Drawings

The User must prepare record drawings to show the recycled water irrigation system as constructed. These drawings must include all changes in the work constituting departures from the original contract drawings including those involving both constant-pressure and intermittent-pressure lines and appurtenances. All conceptual or major design changes must be approved by the agency responsible for approving the plans before implementing the changes in the construction contract. The recycled water irrigation system record drawings must be submitted to the approving agency within thirty (30) days of the site receiving recycled water.

3. Irrigation Equipment Legend

For irrigation systems, a legend showing the pertinent data for the materials used in the system shall be recorded on the plans. The legend shall include a pipe schedule listing pipe sizes and materials of construction; a listing of valve types including quick coupling valves; manufacturer and model number of automatic controller; and the following information for each type of sprinkler head:

- Manufacturer and model number
- Sprinkler radius (feet)
- Operating pressure (psi)
- Flow (gpm)
- Sprinkler pattern
- Precipitation rates
- Nozzle size and/or pressure compensating device size where appropriate

C. General Considerations For Use

1. NSD Access

NSD shall be entitled to reasonable access for the purpose of monitoring and inspecting the recycled water facilities, operations of said facilities, and the use areas. The District shall have access to the customer's premise during the construction periods, as well as whenever the recycled water service is operational.

These inspections are necessary as a condition of the Permit to ensure compliance with NSD and all other applicable standards, and to maintain adequate public safety. The access rights listed in this section shall also apply to the potable water supplier of the site.

2. Public Access

In order to prevent the possibility of unauthorized use, all on-site recycled water facilities shall be restricted from the public so that the general public cannot draw water from the system. Facilities, such as washdown hydrants, blowoff hydrants, blowoffs on strainers and other such facilities shall be restricted from public access. These facilities, both above and below grade, shall be housed in an approved lockable container and posted with a sign as shown in Figure 6.

3. Posting Of Use Areas

All use areas where there is public contact are required to post permanent signs stating the area is irrigated using recycled water. The signs shall measure not less than 8" x 8" with 1" minimum white lettering on a purple background.

Use area signs shall be posted at the direction of the District and in a conspicuous manner to adequately inform the public, especially at access points to the use area. It is the responsibility of the customer to initially post and to maintain necessary identification to the satisfaction of NSD. Signs shall be supplied by NSD and paid for by the customer.

4. Prevention of Overspray, Runoff and Ponding

In accordance with the prohibition on runoff and for control of the areas to which recycled water is applied, the design of irrigation systems shall conform to the following:

- The on-site recycled irrigation system shall be designed to meet the peak moisture demand of all plant materials used within the designated use area.
- On-site recycled irrigation systems shall be designed to prevent or minimize discharge onto areas not under control of the customer. Part circle sprinklers shall be used adjacent to roadways and property lines to confine the sprinklers to the designated use area.

- The design of the on-site recycled irrigation system shall provide for watering during the periods of minimal use of the service area to the extent possible. Consideration shall be given to allow a maximum dry out time before the designated area is used by the public.
- Recycled water shall be applied at a rate which does not exceed the infiltration rate of the soil, thereby avoiding potential runoff. Where varying soil types are present, the design of the recycled irrigation system shall be compatible with the lowest infiltration rate present.

5. Sensitive Areas

Because of increased potential public health risks, some areas within or adjacent to recycled water use areas require special considerations during the design of landscape and irrigation facilities. Generally, additional precautions are necessary to minimize public contact in these areas. Examples are: Exterior drinking fountains and picnic tables must be shown and called out on the recycled water system plans. Note that any drinking fountains and picnic tables which will be located in or adjacent to a recycled water use area require specific approval by NSD.

6. Uses From Domestic Water System

Generally, it is preferred that all irrigation takes place from the recycled water system. However, situations may arise where it is desirable or prudent to irrigate using potable water. If this is the case, care must be exercised to protect against inadvertent cross connection with the recycled water system.

Also, recycled water is only to be used for those purposes specifically permitted in the Permit. If water is needed for purposes not covered by the NSD Permit, then potable water from the domestic water system must be used. Hose bibs and/or quick couplers should be provided on the domestic water system for these purposes.

7. Conversion of Existing Irrigation Systems to Recycled Water

With the exception of pipe identification and pipe separation, facilities where the existing buried piping system is converted from potable to recycled water must meet the same requirements as new facilities. However, any new buried piping added to existing piping at a retrofitted site must meet the identification and separation requirements for new systems. In addition, any existing piping

uncovered for any reason during construction must be marked according to pipe identification requirements to the extent feasible.

D. Design Requirements

1. General

The design and construction of the on-site recycled water distribution system shall, at a minimum, conform to the standards of the UPC, NSD's "Recycled Water Users' Guide", and any other federal, state or local regulations or requirements

2. System Pressure

Every Service from the recycled water system will be no greater than 150 psig, depending upon elevation and distance from the point of supply. With adequate on-site piping, this will be excessive pressure for most irrigation heads, therefore, pressure reducing devices may be required on some irrigation systems.

The District reserves the right to modify its operation in order to increase the reliability or efficiency of the recycled water system, which may result in increases or decreases in delivery pressure.

3. Pressure Regulator

Where the recycled water static service pressure exceeds 80 pounds per square inch, a pressure-regulating valve shall be installed and maintained in the consumer's piping between the meter and the first point of water use, and set at not more than 50 pounds per square inch when measured at the highest fixture on the property served.

This requirement may be waived if the consumer presents evidence satisfactory to NSD that excessive pressure has been considered in the design of water-using devices and that no water will be wasted as a result of high pressure operation.

4. Backflow Prevention

Backflow prevention is required to ensure that recycled water is not inadvertently introduced into a potable water supply. General information on the requirements

for backflow prevention follow, but potential Users should contact NSD for specific information concerning their proposed use.

Backflow protection of the potable water supply to any premises also having a recycled water service is required by the “California Code of Regulations, Title 17 – Public Health, Section 7583 –7605”.

Specifically, §7604, Type of Protection Required, Table 1 (3) states that premises where recycled water is used and there is no interconnection with the potable water system require a “Reduced Pressure Principal Backflow Prevention Device (RP)” In some cases, an “Air Gap” Separation may be required.

Generally backflow protection will not be required on the recycled water service unless such service has provisions for chemical injection or other means of potentially contaminating the recycled water system or when such irrigation system does not meet conditions specified within this manual. Backflow protection may be required for reasons other than recycled water. For backflow protection on the recycled water system, see Figure 1 & 1A.

Backflow preventers shall be tested immediately after they are installed, relocated or repaired and not placed in service unless they are functioning as required.

The installation, testing and maintenance of backflow protection shall be the responsibility of the customer, Title 17, Section 7605.

5. Separation Requirements

A certain degree of separation is necessary between the user’s recycled water and the domestic water system in case of piping damage, failure, or leakage. If minimum separation is not possible, alternate methods will be used to provide the necessary safeguards.

- Basic Separation - Ten feet of undisturbed soil must exist between recycled water and domestic water piping. Recycled water and domestic water piping are not to be installed in a common trench. See Figure 2.
- Less than Basic Separation will only be allowed if there are no other alternatives available, and require prior approval by NSD and the potable water supplier to the site -
 - Not in common trench - If it is required that recycled water and domestic water piping parallel one another in separate trenches

with less than ten feet (10') of undisturbed soil between them, the new line or one of the lines must use schedule 80 pipe. Dig in (marking tape) protection is also required over at least one of the lines. See Figure 4.

- Common trench - Recycled water and domestic water piping can be installed in a common trench only if there are no other alternatives available. The domestic water line shall be placed on a solid shelf excavated at one side of the common trench. The bottom of the water line shall be 12" above the top of the recycled water line. See Figure 3.

The recycled water line shall be minimum Schedule 80 PVC, purple pipe marked "Recycled Water". If purple pipe is not available then marking tape and dig in protection will be required.

Any new domestic water piping shall be minimum Schedule 80 and shall be identified as domestic water piping.

6. Crossings - Sleeves

If recycled water and domestic water lines cross, it is required that such crossing be made perpendicular to each other.

Sleeves shall be required where it is necessary to protect the integrity of either the recycled water or the domestic water system in order to minimize the potential for contamination of the on-site domestic water system. See Figure 5.

Example: Where a constant pressure recycled water line crosses a constant pressure potable water line; a sleeve shall be provided on the recycled water line. The sleeve shall extend not less than 5 feet on each side of the potable water line.

7. Pipe and Dig In Protection

All new recycled water piping systems (including laterals) shall be purple in color and marked "Recycled Water". All constant pressure recycled water piping shall also have metallic dig in protection tape installed in the trench, 8" below and essentially parallel to the finished surface. The tape shall be placed in the trench with the printed side up, and the necessary precautions shall be taken to insure the tape is not pulled, distorted or otherwise misplaced in completing the trench.

8. Depth of On-Site Recycled Water Piping

For on-site recycled water piping, the minimum depth from finished grade to top of pipe (minimum cover) shall be as follows:

1. Constant pressure lines 3-inches and larger - 24"
2. Constant pressure lines 2-1/2 inches and smaller - 18"
3. Intermittent pressure lines - 8" to 12"

Where piping is under paved areas, these dimensions shall be considered below subgrade.

9. Flushing

Customer may desire a method of flushing the recycled water system. Any flushing must be done in such a way that it will not create a hazard or violate the conditions of the Permit. Flushing into the sanitary system is the most acceptable way. If this is not possible, flushing may be done utilizing a tank truck or other approved holding facilities. All holding facilities must be clearly marked. The holding facility shall then be transported and dumped at an approved site in an approved manner.

10. Hose Bibs

Hose bibs are not to be installed on any recycled water system for any purpose. Hose bibs located on the domestic water system and in close proximity to the recycled water system shall be clearly marked as "Potable Water".

11. Washdown Hydrants and Other Points of Public Access

All on-site recycled water facilities shall be restricted from public access so that the general public cannot draw water from the system. Facilities, such as washdown hydrants (typically found at tennis courts), blowoff hydrants, blowoffs on strainers, and other such facilities, shall be restricted from public access.

These facilities, both above and below grade, shall be housed in an approved lockable container with a sign posted as shown in Figure 6. An alternative acceptable means of restricting public access is the use of valves that operate by means of a recessed key slot or by means of pentagonal heads (such as those

typically found on fire hydrants). Other means of restricting public access may be approved by NSD.

12. Quick-Coupling Valves

Quick coupling valves used in the recycled water system shall conform to the following:

1. Quick coupling valves shall be 3/4" or 1" normal size with brass construction and a normal working pressure of 150 psi (Nelson 7642 or 7643 quick coupler with 7640 or 7641 key or approved equal).
2. Valve and key to be coupled using a threaded connection (Nelson 7642 or 7643 quick coupling valve with 7640 or 7641 key or approved equal).
3. A cover shall be permanently attached to the quick coupling valve. The top of the cover shall be purple and read "Non-Potable Water" or other wording as approved by NSD.
4. Locking covers may be required.

13. Flow Meter

All recycled water services shall be metered with an NSD-Approved water meter.

Recycled water meters shall be painted purple. Recycled water meter boxes shall be painted purple on all surfaces.

In certain cases, at NSD's discretion, remote telemetry equipment may be required for recycled water metering, at which time the requirements shall be provided by NSD.

14. Strainers

Sprinkler irrigation systems shall, as necessary, have a "Y" strainer located downstream of the meter. The strainer shall have a 30-mesh or finer screen. Strainers that have automatic backwash features will not normally be allowed unless it can be demonstrated to NSD that the backwash water will not cause runoff and is disposed of in a manner approved by NSD. Strainer drain valve to have a recessed key slot.

15. Control and Regulating Valves

All gates valves, manual control valves, electrical control valves, pressure reducing valves, and pressure relief valves for the on-site recycled water system installed below grade shall be in a valve box with purple interior and carrying the appropriate wording (Recycled Water).

16. Pipe Identification

All new piping, whether for a new or retrofitted system, must be installed according to the approved plans and marked per these requirements to clearly distinguish between recycled water and potable water systems.

- **Identification of Buried Recycled Water Lines**
The use of purple colored pipe with continuous wording "RECYCLED WATER – DO NOT DRINK" printed on opposite sides of the pipe is the preferred method for identification of new buried recycled water piping (constant-pressure mainlines/intermittent-pressure laterals). Pipe must be laid with wording facing upwards.
- **An acceptable alternative: all new buried recycled water lines (constant-pressure mainlines/intermittent-pressure laterals) must be identified by continuous lettering on three inch (3") minimum width, purple marking tape with one inch black or white contrasting lettering bearing the continuous wording "RECYCLED WATER – DO NOT DRINK." This tape must run continuously on top of all piping (mainlines and laterals) and must be attached to piping with plastic tape banded around the marking tape and the pipe every five feet on center. Marking tape must extend to all valve boxes and/or vaults and exposed piping.**
- **Identification of Existing Buried Recycled Water Lines**
Existing buried piping which will be converted to recycled water use need not be marked unless the piping becomes exposed, such as during installation of new pipeline or maintenance of existing pipe. The exposed section must be marked as indicated above for new piping.
- **Identification of Above Grade Recycled Water Lines**
All above grade recycled water pipelines, whether new or existing, must be labeled with the words " RECYCLED WATER - DO NOT DRINK" and color coded purple to differentiate recycled water pipelines from potable water pipelines. If purple identification tape is used to label the

pipe and/or color code the pipe, the tape must be adhesive, permanent, and resistant to environmental conditions. Purple bands may also be painted around the circumference of the pipe at ten-foot intervals for color-coding. Purple PVC pipe is not an acceptable alternative for color-coding because the purple color will fade when exposed to sunlight.

- **Identification of Recycled Water Lines Inside Structures**
Exposed (not buried) constant pressure recycled water irrigation pipelines, such as copper or galvanized pipelines, that might be used in a structure such as a parking garage to route recycled water, must be identified per UPC Appendix J, with the exception that the labeling on the piping must read “CAUTION: RECYCLED WATER – DO NOT DRINK.” Intermittent-pressure lines inside a structure must be identified by affixing decals to this piping at ten-foot intervals and wherever the piping changes directions. These decals must be purple in color and must be imprinted in nominal one-inch-high, black, uppercase letters, with the words “RECYCLED WATER – DO NOT DRINK,” and must be adhesive, permanent, and resistant to environmental conditions.

17. Valve Boxes

All remote control valves, isolation valves, pressure reducing valves, and strainers for on-site recycled water systems must be installed below grade in a valve box. Green, black, or purple valve boxes and lids are acceptable.

Valve boxes must have an advisory label or “nameplate” permanently molded into or affixed onto the lid with rivets, bolts, etc. Labels must be constructed of a purple weatherproof material with the wording "RECYCLED WATER - DO NOT DRINK - NO TOMAR" permanently stamped or molded into the label.

18. Irrigation Controllers

New recycled water system controllers must be automatic with multiple start/stop times for any 24 hour period and installed according to the approved plans and local codes. All recycled water system controllers must be identified by affixing a sticker or “nameplate” to the outside of the controller cabinet, the inside of the controller cabinet, or the outside or inside of the controller cabinet enclosure. Stickers or nameplates must be weatherproof, and must contain wording in English and Spanish indicating that the controller is for a recycled water system.

19. Irrigation and Water Feature Advisory Signs

All use areas where there is public contact are required to post permanent signs stating the area is irrigated using recycled water. The signs shall measure not less than 8" x 8" with 1" minimum white lettering on a purple background.

Use area signs shall be posted at the direction of the District and in a conspicuous manner to adequately inform the public, especially at access points to the use area. It is the responsibility of the customer to initially post and to maintain necessary identification to the satisfaction of NSD. Signs shall be supplied by NSD and paid for by the customer.

20. Miscellaneous Hardware and Appurtenances

All other facilities in the recycled water system not specifically mentioned above shall be suitably labeled to the effect that it is part of the recycled water system. NSD will advise and assist in this type of identification.

E. Inspection

1. Construction Inspection

The District's Engineering Office shall be called for inspection two working days prior to the start of work at (707) 258-6000. The potable water supplier to the site shall also be notified two working days prior to the commencement of work.

2. Cross-Connection Test

The customer shall be responsible for a procedure to determine if a cross-connection exists between the potable water and the recycled water system. The procedure shall be acceptable to NSD and the potable water supplier and the customer shall execute the procedure to the satisfaction of and in the presence of representatives from NSD and the potable water supplier.

3. Final Inspection and Approval to Receive Recycled Water

Before the recycled water irrigation system is connected to recycled water, NSD will perform a final inspection to ensure all requirements have been met. This inspection may be coordinated with the cross-connection test. NSD's inspector will check to see that the proper equipment was used and that all required tags, labels, and signs are in place.

NSD must grant final approval before recycled water can be supplied to the site. Final approval will be granted when construction has been completed in accordance with approved plans and specifications, all cross-connection tests have been performed, a final on-site inspection has been conducted, and all requirements have been met satisfactorily.

After the Recycled Water Use Permit is finalized by NSD, the Water Service Agreement is approved by the local potable water supplier (if applicable), and all applicable fees have been paid, the recycled water meter will be installed.

The State DHS will be forwarded a copy of all test and inspection reports as well as notification that recycled water service has started. During the lifetime of the recycled water system, NSD will periodically inspect the recycled water system to ensure compliance with all applicable rules and regulations.

IV. OPERATIONS & MAINTENANCE

A. Backflow Assembly Monitoring

Title 17 requires testing upon installation and annual testing of backflow prevention assemblies. The potable water supplier will notify the consumer each year of the need to have their potable water service backflow assembly tested by a certified tester. If a backflow prevention device has been installed on the recycled water system, then the consumer will be notified annually by NSD.

Backflow preventers shall be tested at least annually or more frequently if determined to be necessary by the health agency or water supplier. When devices are found to be defective, they shall be repaired or replaced in accordance with the provisions of this Chapter.

Backflow preventers shall be tested immediately after they are installed, relocated or repaired and not placed in service unless they are functioning as required.

B. General Customer Responsibilities

The customer has the responsibility to ensure that the recycled water being used in compliance with the Rules and Regulations issued by the San Francisco Regional Water Quality Control Board, the California Department of Health Services, and NSD. The main concerns are adverse environmental effects or public health problems arising from the misuse of recycled water.

1. Prohibitions

As a condition of use of recycled water, the San Francisco Regional Water Quality Control Board and the Department of Health Services (DHS) have imposed certain common sense limitations to the use of recycled water. Each user of recycled water shall be subject to these limitations and such other limitations as may be determined by NSD:

- The treatment, storage, distribution, or reuse of recycled water shall not create a nuisance as defined in Section 13050(m) of the California Water Code.
- No recycled water shall be applied to irrigation areas during periods when soils are saturated.

- Recycled water shall not be allowed to escape from the designated use area(s) as surface flow that would either pond and/or enter waters of the state.
- Spray or runoff shall not enter a dwelling or food handling facility, and shall not contact any drinking water fountain, unless specifically protected with a shielding device.
- The use of recycled water shall not cause rising groundwater discharging to surface waters to impair surface water quality objectives or beneficial uses.
- The use of recycled water shall not unreasonably affect present and anticipated beneficial uses of water, and not result in water quality less than that prescribed in water quality control plans or policies.
- No recycled water shall be discharged from treatment facilities, irrigation holding tanks, storage ponds, or other containment, other than for permitted reuse in accordance with this Reuse Program, specific Board Issued Water Discharge Requirements, or for discharge to a municipal sewage treatment system.
- Recycled water shall not be used as a domestic water supply or as an animal supply.
- There shall be no cross-connection between potable water supply and piping containing recycled water. All users of recycled water shall provide for appropriate backflow protection for potable water supplies as specified in Title 17, Section 7604 of the California code of Regulations or as specified by DHS.

C. Monitoring And Reporting

1. General

The principle purposes of a monitoring program by a reclaimed water producer or user, also referred to as a self-monitoring program, are:

1. To document compliance with reclaimed water requirements and prohibitions established by the Regional Board; and,
2. To facilitate self-policing by the reclaimed water producer and in the prevention and abatement of pollution arising from water reuse.

2. Violations

If serious and/or repeated violations are discovered regarding a recycled water service, NSD will discontinue service until such time that the violations are

corrected to the satisfaction of NSD. Violations include, but are not limited to, the following:

1. Violation of Recycled Water Use Permit.
2. Unauthorized connections or plumbing.
3. Cross-connections
4. Violations of NSD standards.
5. Situations that compromise or jeopardize public health.

If violations are found a NSD representative will send you a "Notice of Non-Compliance". See Form in Appendix A.

3. Users' Monitoring Reports

The "User Supervisor" shall conduct visual monitoring observations of each use area. Such monitoring observations shall be conducted at a time while recycled water is being used and at least a minimum of once each week for each user.

Observations shall be for the purpose of determining user compliance with provisions of the reuse permit.

1. Standard Observations
 - a. Evidence of runoff of recycled water from the site (show affected area on a sketch, estimate volume).
 - b. Odor of wastewater origin from irrigation site. If present, indicate apparent source, characterization, and direction of travel.
 - c. Evidence of ponding of recycled water, and evidence of mosquitoes breeding within the irrigation area due to ponded water.
 - d. Warning signs properly posted to inform public that irrigation or water use is recycled water which is not safe for drinking.
 - e. Evidence of leaks or breaks in the irrigation system pipelines or tubing.
 - f. Evidence of broken or otherwise faulty drip irrigation system emitters or spray irrigation sprinklers.
 - g. Evidence of overflows, leaks, erosion of dikes, etc. of storage pond(s) or impoundment(s).

2. Description of Sampling and Observation Stations

a. Land Observation Stations

<u>Station</u>	<u>Description</u>
L-1 to L-n	Locations at a sufficient number of points at reuse areas in order to ensure compliance with water reuse requirements.

b. Impoundment Stations

<u>Station</u>	<u>Description</u>
P-1 to P-n	Locations at points along the periphery of each storage, ornamental, golf course, or other pond or impoundment.

Appendix B contains a sample monitoring report and observation site map. The site map need only be provided with the first observation report, and subsequent reports when locations are changed or a violation occurs. (See Figure 7.) In case of street landscaping, planter boxes, traffic islands, etc., it is suggested that the use area be consolidated or grouped, and the monitoring stations indicated on a street map.

Visual monitoring stations must be at a sufficient number of points at reuse areas in order to ensure compliance with water reuse requirements. Observations to be noted are those specifically required as part of the operating permit, runoff, odors, ponding, overspray or any other undesirable conditions resulting from the use of recycled water.

Any area that has had recycled water applied during the preceding month must be included in the user's monthly monitoring report. Copies of the monthly monitoring report shall be sent to NSD by no later than the 5th day of the following month.

D. User Supervisor

1. User Supervisor Designation

As a condition of recycled water service each applicant shall maintain at least one person who is knowledgeable in the irrigation system and irrigation practices of the consumer. Said person shall be designated as a "User Supervisor". See form in Appendix "B".

The “User Supervisor” shall be responsible for ensuring compliance with all Federal, State, Local and District rules and regulations and policies pursuant to recycled water service.

2. User Supervisor Training

NSD shall provide training to the User Supervisor in the proper use of recycled water. It is the responsibility of the User Supervisor to ensure that his or her personnel are informed about the proper and safe use of recycled water.

3. Changing the User Supervisor

NSD shall be immediately notified if the Designated User Supervisor is changed, and a new “User Supervisor Designation Form” shall be provided to NSD two working days.

4. User Supervisor Responsibilities

The "User Supervisor" shall conduct visual monitoring observations of each use area. Such monitoring observations shall be conducted at a time while recycled water is being used and at least a minimum of once each week for each user.

Observations shall be for the purpose of determining user compliance with provisions of the reuse permit.

The User Supervisor is responsible for timely submittal of monthly reports to NSD.

The User Supervisor is responsible for timely notification of unauthorized discharges of recycled water pursuant to the following flow chart

**Reporting Requirements for
Incidental Runoff
2/29/2008**

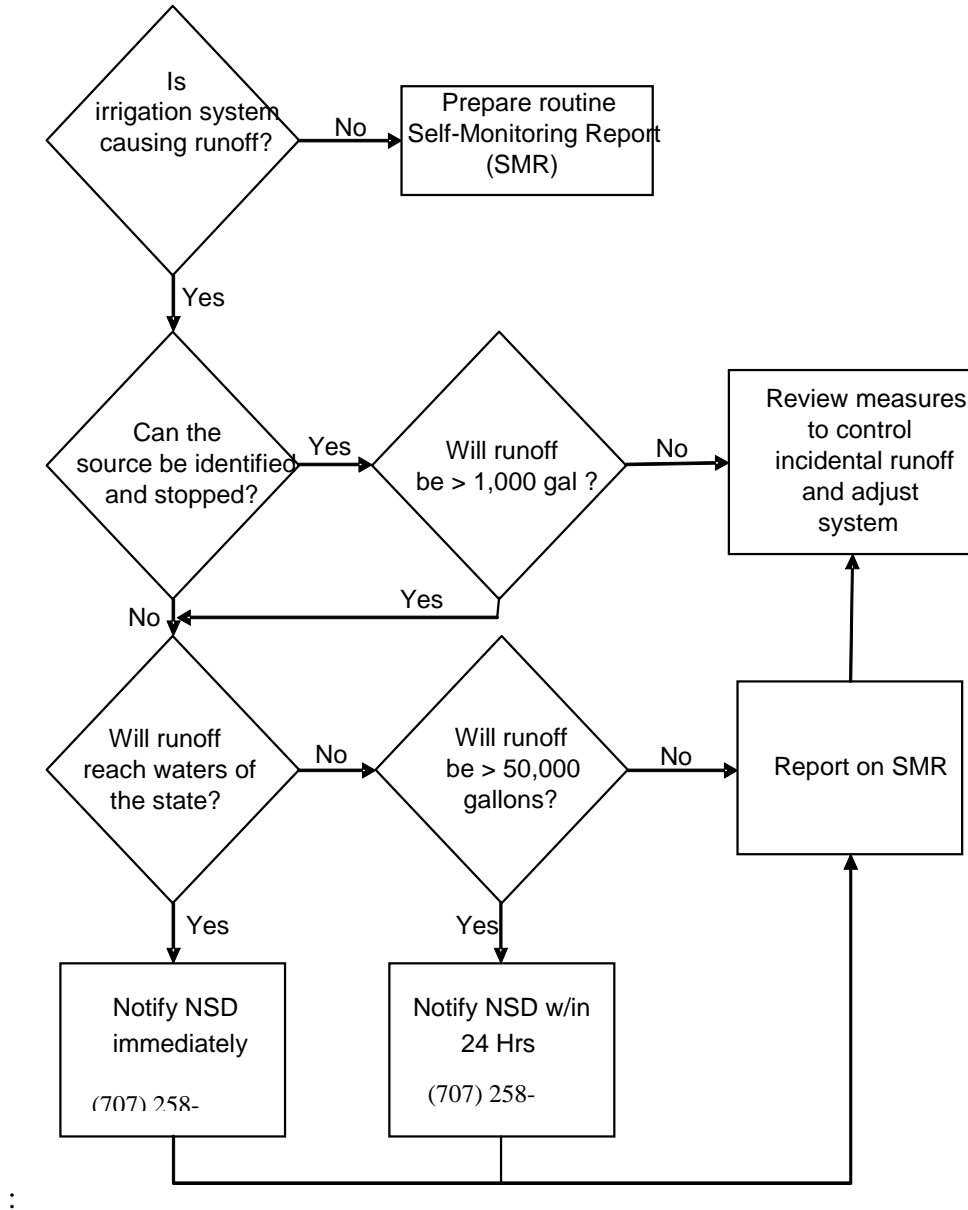

5. Personnel Training

The User Supervisor is responsible for training all personnel involved with recycled water so they are familiar with the requirements of a recycled water system. At a minimum, the training program should convey the following information:

- Recycled water, although highly treated, is non-potable and must never be used for human consumption.
- Regulations prohibit ponding, windblown spray and runoff of recycled water.
- Working with nonpotable recycled water is safe if common sense is used and appropriate regulations are followed.
- State law prohibits a connection between the recycled water and the potable water systems.

Training programs should also instruct personnel in proper procedures for reporting unauthorized discharges, identifying and correcting cross connections, and modifying the system in the event of an earthquake or other disaster.

E. Emergency Cross-Connection Procedures

The User must notify the local potable water supplier and NSD by telephone immediately. This notification must be followed by a written notice within 24 hours that includes an explanation of the nature of the cross-connection, date and time discovered, and the contact information of the person reporting the cross-connection.

The customer must immediately shut down the recycled water supply to the facility.

The local potable water supplier or NSD will notify Napa County Public Health - Environmental Health Division and State DHS of the reported cross-connection.

The customer must keep the potable system pressurized and post "Do Not Drink" signs at all potable water fixtures and outlets.

The customer must provide bottled water for employees until the potable water system is deemed safe to drink.

The customer must follow the procedures outlined by Napa County Public Health - Environmental Health Division, State DHS, NSD, and the local potable water supplier.

After final approval has been obtained from Napa County Public Health – Environmental Health Division and State DHS, the local potable water supplier will allow the recycled

water system to be brought back into service and inform the customer to remove the "Do Not Drink" signs from all potable water fixtures and outlets.

APPENDICIES

This page intentionally left blank.

APPENDIX A - FIGURES

- FIGURE 1** TYPICAL RECYCLED WATER BACKFLOW PREVENTION DEVICE INSTALLATION
- FIGURE 2** SYSTEM SEPARATION REQUIREMENTS: PIPE SEPARATION
- FIGURE 3** SYSTEM SEPARATION REQUIREMENTS: COMMON TRENCH
- FIGURE 4** DIG IN PROTECTION INSTALLATION
- FIGURE 5** SLEEVING OF RECYCLED WATER PIPING
- FIGURE 6** RECYCLED WATER SIGN
- FIGURE 7** OBSERVATIONS STATION MAP (EXAMPLE)

FIGURE 1 -TYPICAL RECYCLED WATER BACKFLOW PREVENTION DEVICE INSTALLATION

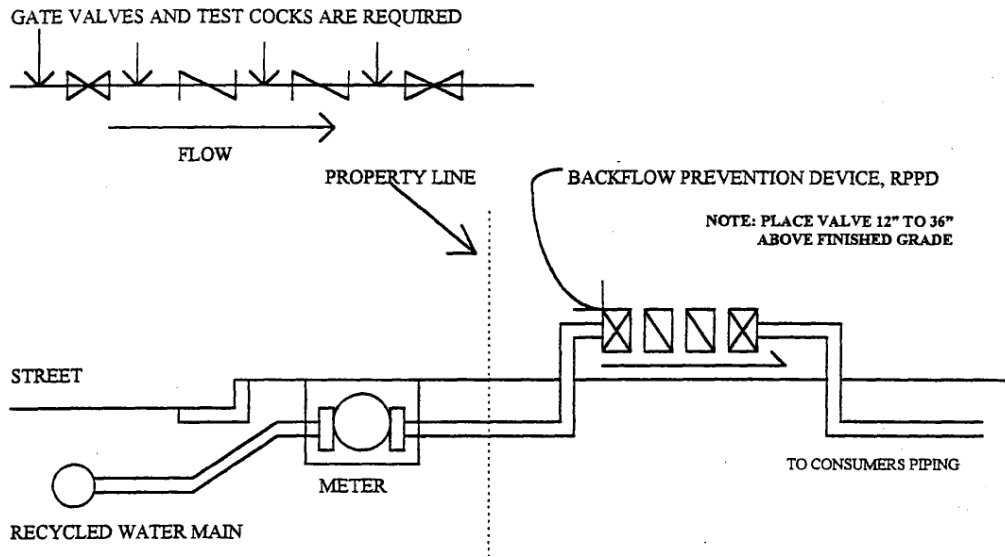

NOTES:

1. The device shall be approved by NSD and conform with American Water Works Association Specification C506, latest revision. Any deviation from the methods described above must receive approval prior to installation.
2. The device shall be installed on the property side of and adjacent to the meter.
3. The supply pipeline between the meter and the backflow prevention device must be exposed only for initial inspection purposes.
4. The device shall be installed in an easily accessible location; the bottom of the device shall be at least 12" to 36" above finished grade. The device must be installed in a horizontal position to the horizon.
5. Alternate locations will be evaluated for acceptability if desired.
6. There shall not be any outlet, tee, tap or connection of any kind to or from the supply pipeline between the recycled water meter and the backflow protective device.
7. No bypasses of any kind or for any duration will be permitted without an equivalent backflow prevention assembly being installed in the line and without prior approval of NSD.
8. Installation of a backflow device will make the piping downstream of the device (your piping) a "closed system". If the water expands (due to change in ambient temperature or heat), the water pressure in a closed system will increase. It is important that the piping be equipped with the proper pressure relief valve, preferably on the hot water system.

FIGURE 2 - SYSTEM SEPARATION REQUIREMENTS: PIPE SEPARATION

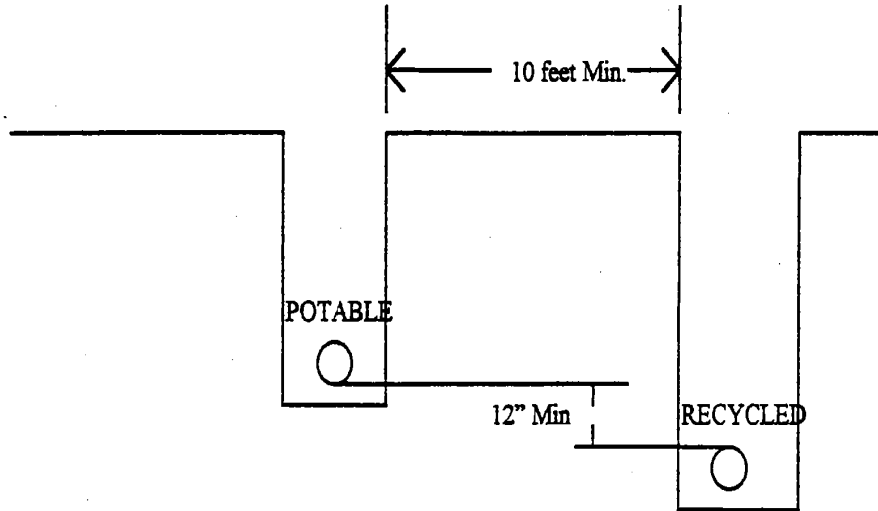

Ten feet of undisturbed soil must exist between recycled water and domestic water piping. Recycled water and Domestic water piping are not to be installed in a common trench with less than the minimum separation. (See Figure 3 for exceptions to the “Basic Separation Rule”.)

FIGURE 3 - SYSTEM SEPARATION REQUIREMENTS: COMMON TRENCH

MUST BE APPROVED BY NSD AND POTABLE WATER PURVEYOR

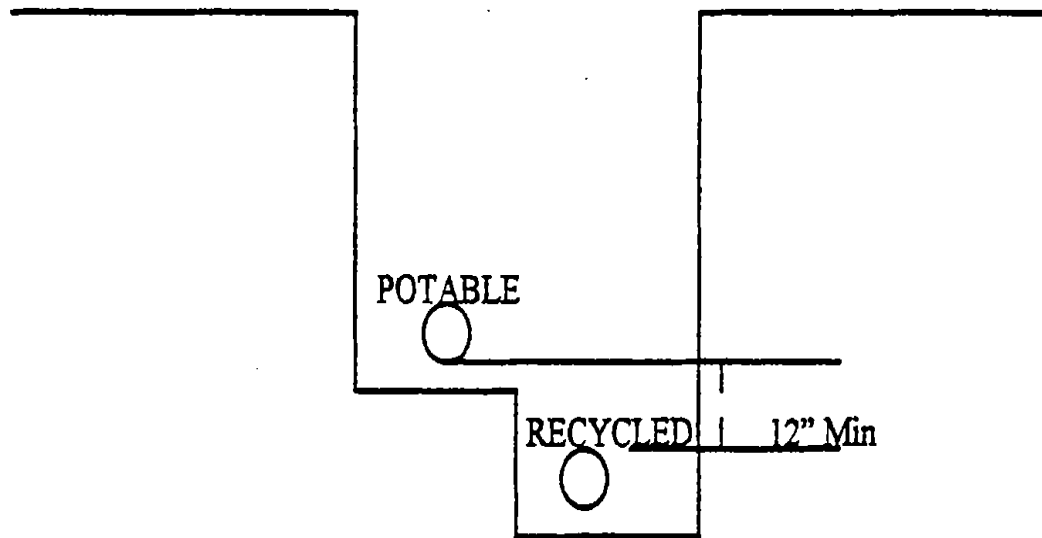

Recycled water and domestic water piping can be installed in a common trench only if there are no other alternatives available. The domestic water line shall be placed on a solid shelf excavated at one side of the common trench. The bottom of the domestic water line shall be a minimum of 12 inches above the top of the recycled water line. Additional corrosion protection should be considered on the domestic water line.

FIGURE 4 - DIG IN PROTECTION INSTALLATION

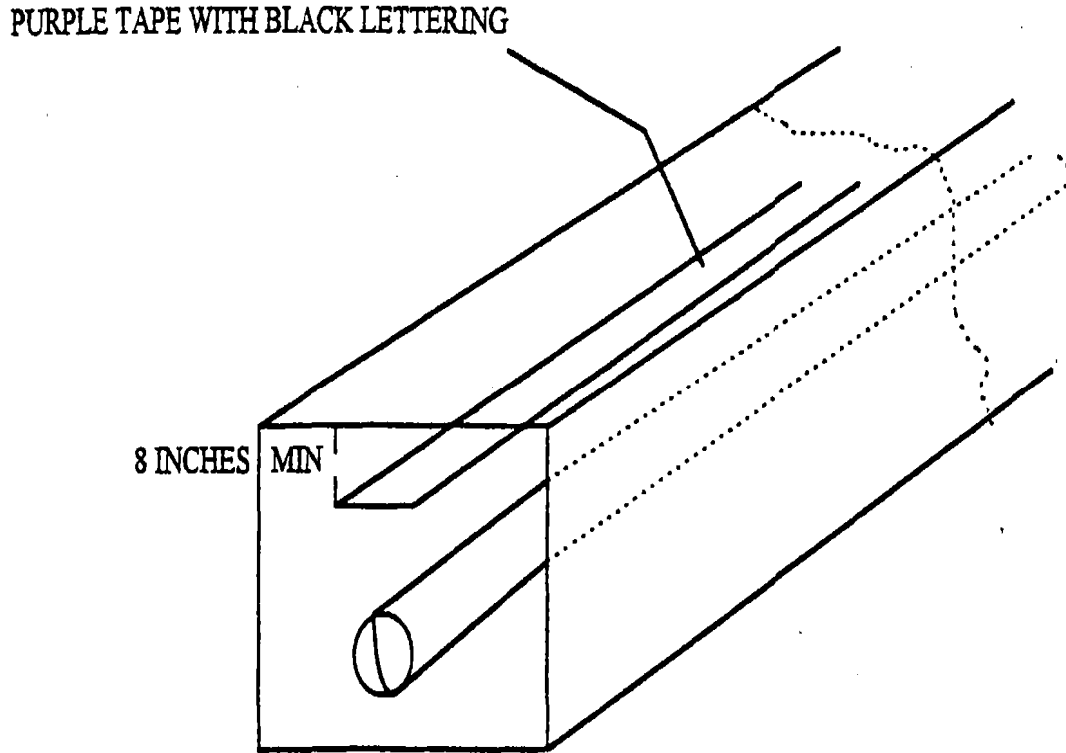

Where dig in protection is specified, 6" wide terra tape, as manufactured by Griffolyn Company, Inc., 10020 Mykawa Road, P.O. Box 33248, Houston, Texas 77033; phone (800) 231-6074, or equal is required. Tape shall be purple with black lettering – "CAUTION RECLAIMED WATER LINE BURIED BELOW – DO NOT DRINK" (Stock item). Dig in protection tape shall be installed 8" below the surface. The tape shall be placed in the trench with the printed side up, and be essentially parallel to the finished surface. The necessary precautions must be taken to insure the tape is not pulled, distorted or otherwise misplaced in completing the trench

FIGURE 5 - SLEEVING OF RECYCLED WATER PIPING

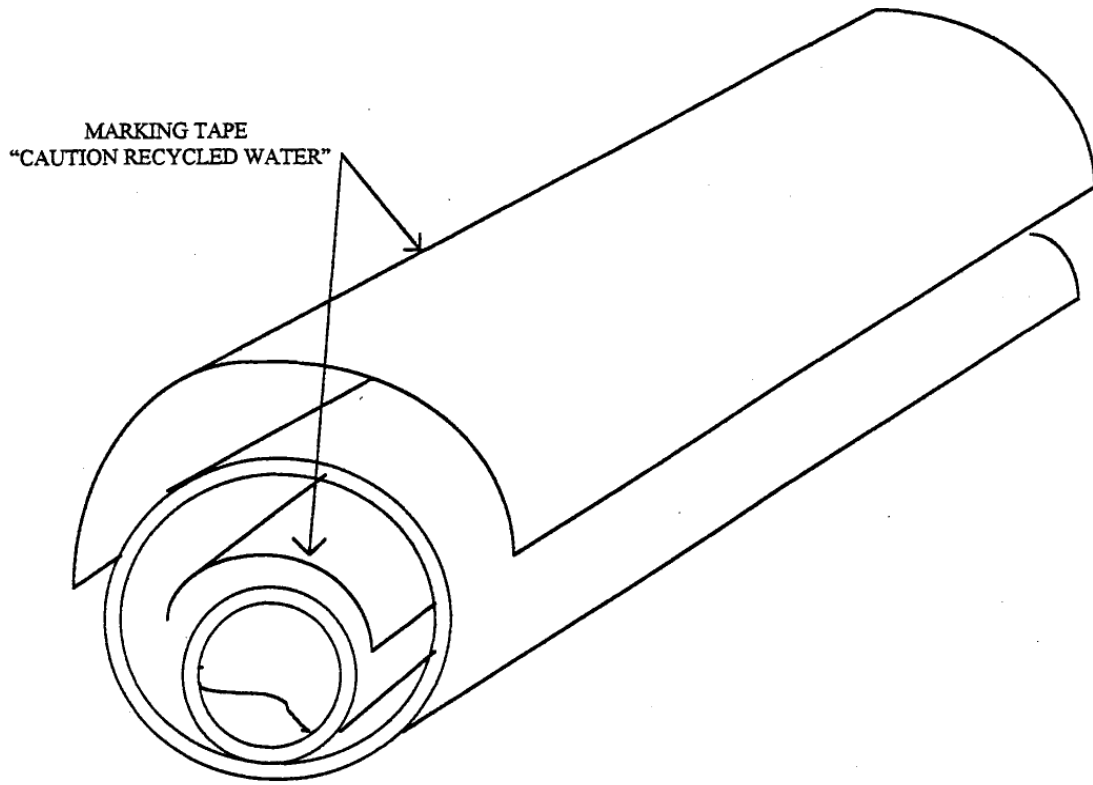

The recycled water sleeve shall be ductile iron. Both pipe and sleeve shall be identified as recycled water piping.

FIGURE 6 - RECYCLED WATER SIGN



The Recycled Water Sign to be posted at washdown hydrants, blowoff hydrants, blowoffs on strainers and other such facilities, shall measure not less than 8" by 8". The sign shall have a purple background with 1/2" minimum white lettering which reads "RECYCLED WATER – DO NOT DRINK" "NO TOMAR AGUA", the circle/slash shall be 5" in diameter and red in color. The figurehead and cup shall be white. (See page 24, item F for guidelines to signs posted at use areas).

FIGURE 7 - OBSERVATIONS STATION MAP (EXAMPLE)

Name of User: _____ Date: _____

Location: _____

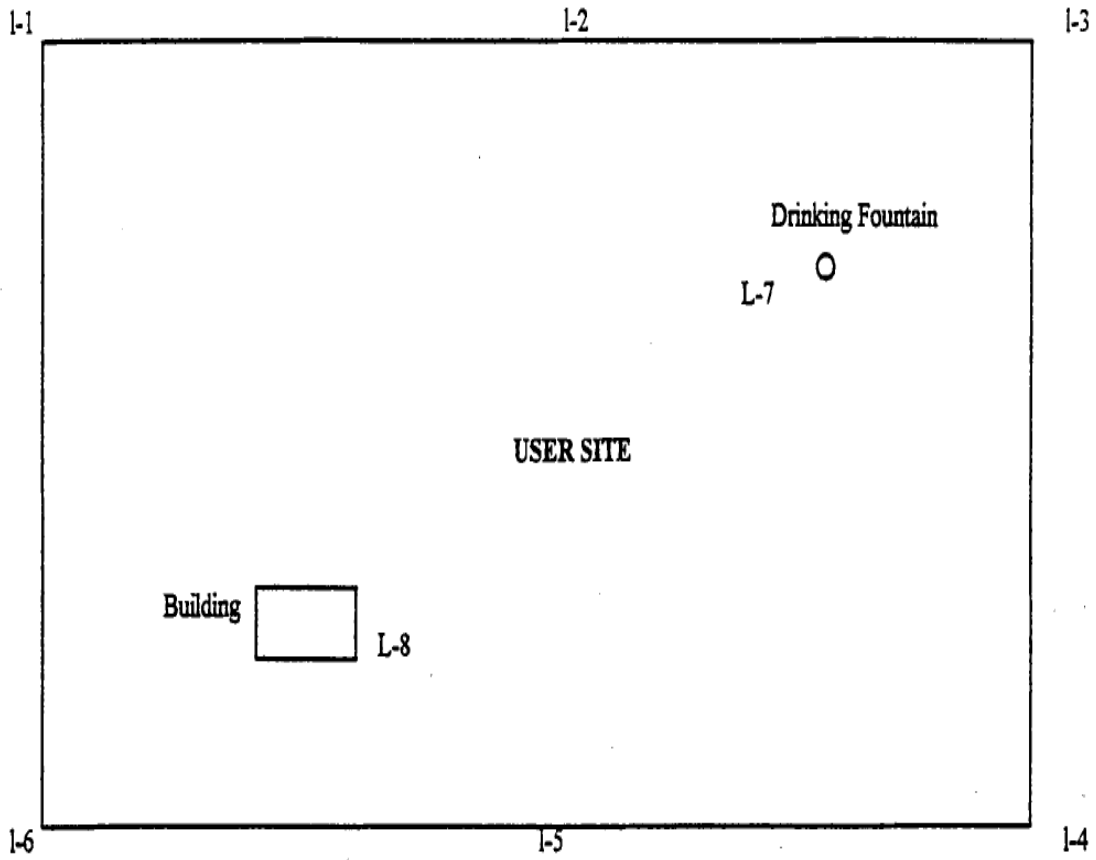

l = Visual monitoring Stations

APPENDIX B - FORMS

APPLICATION PACKET

1. Application for Connection to Recycled Water Service
2. Designation of User Supervisor
3. Recycled Water Backflow Protection – Environmental Assessment Information Sheet
4. Recycled Water Supervisor's Initial and Monthly Cross-Connection Monitoring Form
5. Permanent Service Recycled Water Use Permit
6. Recycled Water User Self-Monitoring Report
7. Recycled Water User Notice of Non-Compliance
8. Guidelines for Worker Protection at Water Reclamation Use Areas

APPLICATION CHECKLIST

1. Irrigation Plans for Review
 - a. Pipes, valves, sizes, schematic
 - b. Other outlets and appurtenances
2. Requirements for Service
 - a. Prohibitions (User Guidelines)
3. Completed Application for Recycled Water Service (including signed agreement).
4. Completed Designation of User Supervisor
5. Completed "Recycled Water Backflow Protection - Environmental Assessment Information Sheet" and "Recycled Water Supervisor's Initial and Monthly Cross Connection Monitoring Form"
6. Backflow Protection - type and location, test form (recycled water).
7. Backflow Protection - Verification from potable water supplier of completed backflow installation.
8. Turn On Notice (Recycled)
9. Notice to potable water supplier of recycled water service to site.

* ITEMS 1 THROUGH 6 SHALL ALSO BE SUBMITTED TO THE POTABLE WATER SUPPLIER

Napa Sanitation District
1515 Soscol Ferry Rd
Napa, CA 94558
(707) 258-6000

APPLICATION FOR CONNECTION TO RECYCLED WATER SERVICE

- New Service

- New Ownership (Explain) _____

- Modified Service (Explain) _____

Owner's Name: _____ Phone: _____

Street Address: _____ City & Zip: _____

Address of Property to be Served: _____

ASSESSORS PARCEL No. _____

Street Address: _____ City & Zip: _____

Description of Area to be Served (Include 8.5 X 11 Site Map, Exhibit "A" of Agreement):

TYPE OF USE (check all that apply)

APPLICATION METHOD: DRIP SPRAY FLOOD OTHER*

* _____

USE OF WATER: _____

Estimated Volume (gallons) of Recycled Water Needed Per Day: _____ Per Year: _____

I UNDERSTAND AND AGREE TO ALL CONDITIONS FOR RECYCLED WATER SERVICE AS SET FORTH IN THIS APPLICATION AND HEREBY CERTIFY UNDER PENALTY OF PERJURY THAT THE INFORMATION PROVIDED IN THIS APPLICATION AND IN ANY ATTACHMENTS IS TRUE AND ACCURATE TO THE BEST OF MY KNOWLEDGE. I ALSO CERTIFY THAT I HAVE READ AND AGREE TO ABIDE BY ALL CONDITIONS OF THE NSD RECYCLED WATER PROGRAM WHICH INCLUDE CONDITIONS SET FORTH IN THE RWQCB's GENERAL REUSE ORDER # 96-011.

OWNER / USER: _____ DATE: _____

Signature

DESIGNATION OF USER SUPERVISOR

Date: _____

Owners Name: _____

Company Name: _____

Address: _____

City: _____ State & Zip: _____

Phone: () _____ Fax () _____

User Supervisor: _____

Address: _____

ASSESSORS PARCEL No. _____

City: _____ Zip Code: _____

Phone (Day): () _____ Evening: () _____

FAX: () _____

FOR NSD USE ONLY

Approved

Rejected

Comments:

Date: _____

Approval Signature

**RECYCLED WATER SYSTEM BACKFLOW PROTECTION –
ENVIRONMENTAL ASSESSMENT and INFORMATION SHEET**

USERS NAME: _____ DATE: _____

MAILING ADDRESS: _____ CITY: _____

STATE: _____ ZIP: _____ PHONE: _____

SERVICE ADDRESS: _____

ASSESSORS PARCEL No. _____

TYPE OF FACILITY (check all that apply)

1. Residential	Industrial	Commercial	Irrigation
<input type="checkbox"/> Single Family	<input type="checkbox"/> Lease/Rental	<input type="checkbox"/> Boiler	<input type="checkbox"/> Domestic
<input type="checkbox"/> Duplex Unit	<input type="checkbox"/> Light Manufacturing	<input type="checkbox"/> Cooling Tower	<input type="checkbox"/> Agriculture
<input type="checkbox"/> Triplex	<input type="checkbox"/> Heavy Manufacturing	<input type="checkbox"/> Recirculating Pump	<input type="checkbox"/> Chemical Injection
<input type="checkbox"/> Multiple Units	<input type="checkbox"/> Marine Complex	<input type="checkbox"/> Industrial Water	<input type="checkbox"/> Drip irrigation
<input type="checkbox"/> Other	<input type="checkbox"/> Other	<input type="checkbox"/> Other	<input type="checkbox"/> Other

Description of Water Uses: _____

YES NO

1. Is there a developed Spring, Creek or Well on or available to this site?
2. Will there be more than one recycled water service to this property?
3. Will there be provisions for chemical injection into irrigation system?

I declare under penalty of perjury all of the above statements are true and correct. Backflow requirements may be imposed at any future time commensurate with the degree of hazard as established by NSD.

Signature: _____ Date: _____

Owner and/or Representative

Note: This form is to assess the need for backflow protection on the recycled water system

This Box for NSD use only	
BACKFLOW PROTECTION REQUIRED	APPROVED _____
BACKFLOW PROTECTION <u>NOT</u> REQUIRED	APPROVED _____

**RECYCLED WATER SUPERVISOR'S INITIAL AND MONTHLY
CROSS CONNECTION MONITORING FORM**

USER: _____

ADDRESS: _____

MONTH: _____ YEAR: _____

_____ YES _____ NO Has any additional plumbing been added during this monitoring period, (If no, then check "No", sign and return to NSD and the potable water purveyor by the 5th day of the following month)

If "YES" then the system must be checked for accidental Cross Connections.

Suggested procedure for checking for Cross Connections.....

1. Turn the potable water supply off at the water meter.
2. Make sure the recycled water system is pressurized.
3. Check faucets, drinking fountains and other potable water outlets for water pressure.

Results:

- A. _____ No pressure on potable water system, OK
- B. _____ Pressure on potable water system---determine source of pressure and correct.

If "B" is checked, explain corrective action taken.

If another method is used to check for Cross Connections, User is to provide NSD with a written statement outlining procedure used.

I declare under penalty of perjury all of the above statements are true and correct.

Signature of Designated User Supervisor

Date

Return Completed form to:

Napa Sanitation District
Attn: Reclamation System Director
1515 Soscol Ferry Rd
Napa, CA 94558

cc: Potable Water Supplier

PERMANENT SERVICE RECYCLED WATER USE PERMIT

USER INFORMATION

NAME OF USER: _____ Phone: _____
ADDRESS: _____
USER SUPERVISOR: _____ Phone: _____
ADDRESS OF PROPERTY SERVED: _____
ASSESSORS PARCEL No. _____

TYPE OF USE (check all that apply)

APPLICATION METHOD: DRIP SPRAY FLOOD OTHER*

* _____

USE OF WATER: _____

PRODUCER INFORMATION (District Use Only)

LEVEL OF TREATMENT TERTIARY 2.2 MPN

VOLUME OF RECYCLED WATER AUTHORIZED PER DAY: _____ GALS. PER YEAR _____ MG

SERVICE No. _____

WORK ORDER No. _____ SERVICE SIZE _____ INCHES

<u>FEE SCHEDULE:</u>	<u>DESCRIPTION</u>	<u>AMOUNT</u>
	INSPECTION FEES	_____
	METER INSTALLATION CHARGE	_____
	RECYCLED WATER SIGNS AT \$10.50 EA.	_____
	OTHER _____	_____
	TOTAL RECEIVED	_____

PRODUCER: Napa Sanitation District
ADDRESS 1515 Soscol Ferry Rd Napa, CA. 94558

This Permit is conditionally issued by the Napa Sanitation District for the use of recycled water at properties herein stated. Prior to any alteration in the type of use or property location written approval must be obtained from NSD. Failure to obtain approval shall void this permit. The neglect or misuse of the recycled water system herein stated shall result in immediate termination of recycled water service. The Permittee agrees to read and agree to abide by the RWQCB Order # 96-011 and maintain compliance with District rules and regulations subject to recycled water use. **The Department of Health Services shall review planned new uses that are not covered under the proposed revisions to the California Code of Regulations, Title 22, water reuse regulations, and new uses requiring disinfected tertiary reclaimed water.**

AUTHORIZED AGENT OF USER: _____ DATE: _____
Signature

PRODUCER: _____ DATE: _____
Signature

EFFECTIVE DATE OF PERMIT: _____

RECYCLED WATER USER SELF-MONITORING REPORT

USER: _____

ADDRESS: _____

MONTH: _____

YEAR: _____

A SUFFICIENT NUMBER OF OBSERVATION STATIONS MUST BE ESTABLISHED AROUND THE USE SITE TO ENSURE THAT COMPLIANCE WITH THE REUSE PERMIT REQUIREMENTS IS BEING MET. A MAP SHOWING THE LOCATION OF THE OBSERVATION STATIONS MUST BE SUBMITTED WITH THE FIRST OBSERVATION REPORTS. EACH OBSERVATION STATION MUST BE INSPECTED AT LEAST ONCE PER WEEK.

DATE	YES / NO	YES / NO	YES / NO	YES / NO	YES / NO
OBSERVATION STATIONS INSPECTED					
RECYCLED WATER ESCAPE FROM SITE					
ODORS FROM RECYCLED WATER					
PONDING OF RECYCLED WATER					
MOSQUITO BREEDING					
WARNING SIGNS NOT PROPERLY POSTED					
SPRAY ON WATERWAYS, VEHICLES, ETC.					

I certify that the information in this report, to the best of my knowledge, is true and correct

Signature of Designated User Supervisor

Date

Return Completed form to:

Napa Sanitation District
Attn: Reclamation System Director
1515 Soscol Ferry Rd
Napa, CA 94558

RECYCLED WATER USER
NOTICE OF NON-COMPLIANCE

Recycled Water User Name: _____

Address: _____

On _____ the following violation (s) of recycled water use regulations was/were found:

CLASS I Violation (correct in 7 days)

_____ Irrigation during the daytime at _____. Adjust your time clock to night -time setting between 10:00 P.M. and 6:00 A.M.

_____ Adjust sprinklers to avoid spraying areas with human contact, i.e. (sidewalks, roads, benches, picnic tables, patios, and drinking fountains).

_____ Broken sprinkler head.

_____ Ponding and/or runoff – adjust sprinkler times.

_____ Above-ground sprinklers need “Recycled Water – Don Not Drink” stickers.

CLASS II Violation (correct in 30 days)

_____ Leak found on _____ (valve, pipe, etc.)

_____ Remove hose bib or install quick coupler.

_____ Recent excavation noted. If pipelines have been relocated please submit changes immediately to NSD.

_____ Recycled Water being used outside the design area – relocate piping

_____ Other: _____

CLASS III Violation (correct before recycled water service can be resumed)

_____ Cross connection between recycled and potable found. Recycled water has been locked off until problem is corrected.

_____ Broken valves and/or pipelines. Water has been discontinued until repair can be made.

_____ Other: _____

Comments: _____

_____ Surveillance Inspector

_____ Date _____

GUIDELINES FOR WORKER PROTECTION AT WATER RECLAMATION USE AREAS

1. Employees should be made aware of the potential health hazards involved with contact or ingestion of reclaimed water.
2. Adequate first aid kits should be available on location, and all cuts and abrasions should be treated promptly to prevent infection. A doctor should be consulted where infection is likely.
3. Precautionary measures should be taken to minimize direct contact of employees with reclaimed water
 - a. Employees should avoid being sprayed with reclaimed water.
 - b. At crop irrigation sites, the crops and soil should be allowed to dry before harvesting.
4. Provisions should be made for a supply of safe drinking water for employees. Where bottled water is used for drinking purposes, the water should be in contamination proof containers and protected from contact with reclaimed water or dust.
 - a. The water should be of a source approved by the local health authority.
5. Washing facilities should be provided.
6. Precautions should be taken to avoid contamination of food taken to areas irrigated with reclaimed water.
7. Adequate means of notification should be provided to inform the employees reclaimed water is being used. Such notification should include posting of conspicuous warning signs with wording of sufficient size to be clearly read.
8. All reclaimed water valves and outlets should be appropriately tagged to warn employees that the water is not safe for drinking or direct contact (direct contact is allowed at non restricted recreational impoundments).
9. All piping, valves and outlets should be color-coded or other wise marked to differentiate reclaimed water from domestic or other water.
 - a. Where feasible, differential piping material should be used to facilitate water system identification.
10. All reclaimed water valves, outlets and sprinkler heads should be of a type that can only be operated by authorized personnel.
 - a. Where hose bibs are present on domestic and reclaimed water lines, differential sizes should be established to preclude the interchange of hoses.

This page intentionally left blank.

* * * End of NSD Recycled Water Users' Guide * * *